



Fall Protection

Introducing the
3M™ DBI-SALA® Flexiguard™
Modular Jib System.

The next level of jib versatility.



Complies with

EN 795.2012 | CEN/TS 16415:2013 | OSHA 1962.502 | OSHA 1910.140

M100 & M200

Exceptional configuration compatibility.

Improved transportability.

Helps you work safely.

Get the coverage you need with this versatile new fall protection system. Available in both the M100 and M200 Series, the 3M™ DBI-SALA® Flexiguard™ Modular Jib System features a simplified design that enhances worker safety in multiple applications. Increased rail-length configurations improve working coverage while a new design facilitates easier system transport.

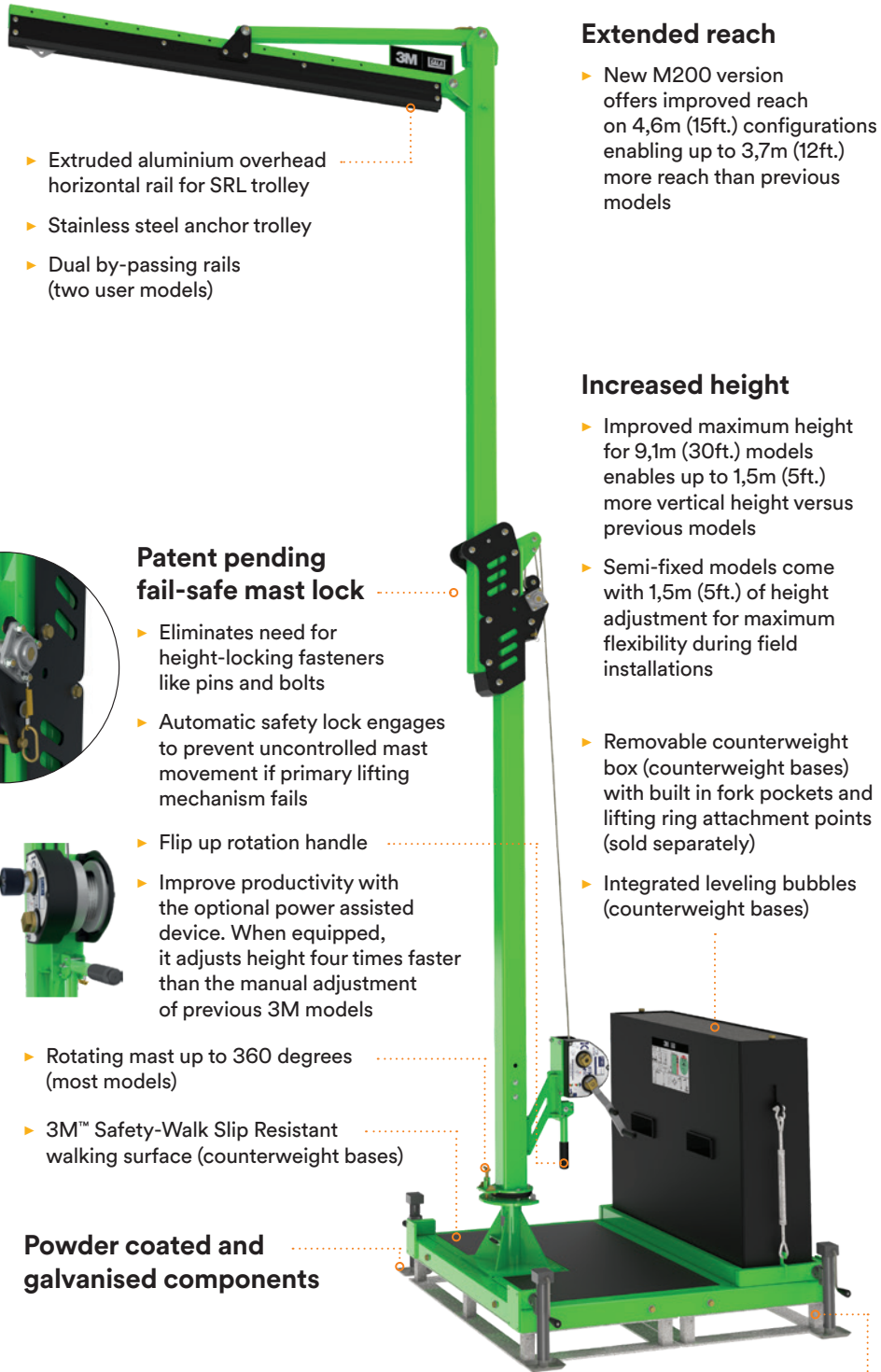

- ▶ Extruded aluminium overhead horizontal rail for SRL trolley
- ▶ Stainless steel anchor trolley
- ▶ Dual by-passing rails (two user models)

Patent pending fail-safe mast lock

- ▶ Eliminates need for height-locking fasteners like pins and bolts
- ▶ Automatic safety lock engages to prevent uncontrolled mast movement if primary lifting mechanism fails
- ▶ Flip up rotation handle
- ▶ Improve productivity with the optional power assisted device. When equipped, it adjusts height four times faster than the manual adjustment of previous 3M models
- ▶ Rotating mast up to 360 degrees (most models)
- ▶ 3M™ Safety-Walk Slip Resistant walking surface (counterweight bases)

Powder coated and galvanised components

Extended reach

- ▶ New M200 version offers improved reach on 4,6m (15ft.) configurations enabling up to 3,7m (12ft.) more reach than previous models

Increased height

- ▶ Improved maximum height for 9,1m (30ft.) models enables up to 1,5m (5ft.) more vertical height versus previous models
- ▶ Semi-fixed models come with 1,5m (5ft.) of height adjustment for maximum flexibility during field installations
- ▶ Removable counterweight box (counterweight bases) with built in fork pockets and lifting ring attachment points (sold separately)
- ▶ Integrated leveling bubbles (counterweight bases)

- ▶ Open multi-directional base designed to accommodate a wide array of fork shapes and sizes

More versatility

New modular product offering provides

80 unique application solutions

Enhanced safety working area.

- ▶ Extended rail-lengths increase safe working area coverage
- ▶ Reduces risk of potential swing fall hazards – worker and safety manager can visually verify the straight vertical boundary
- ▶ Simplifies fall clearance requirements

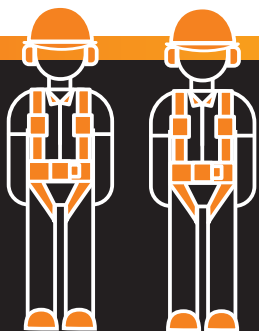
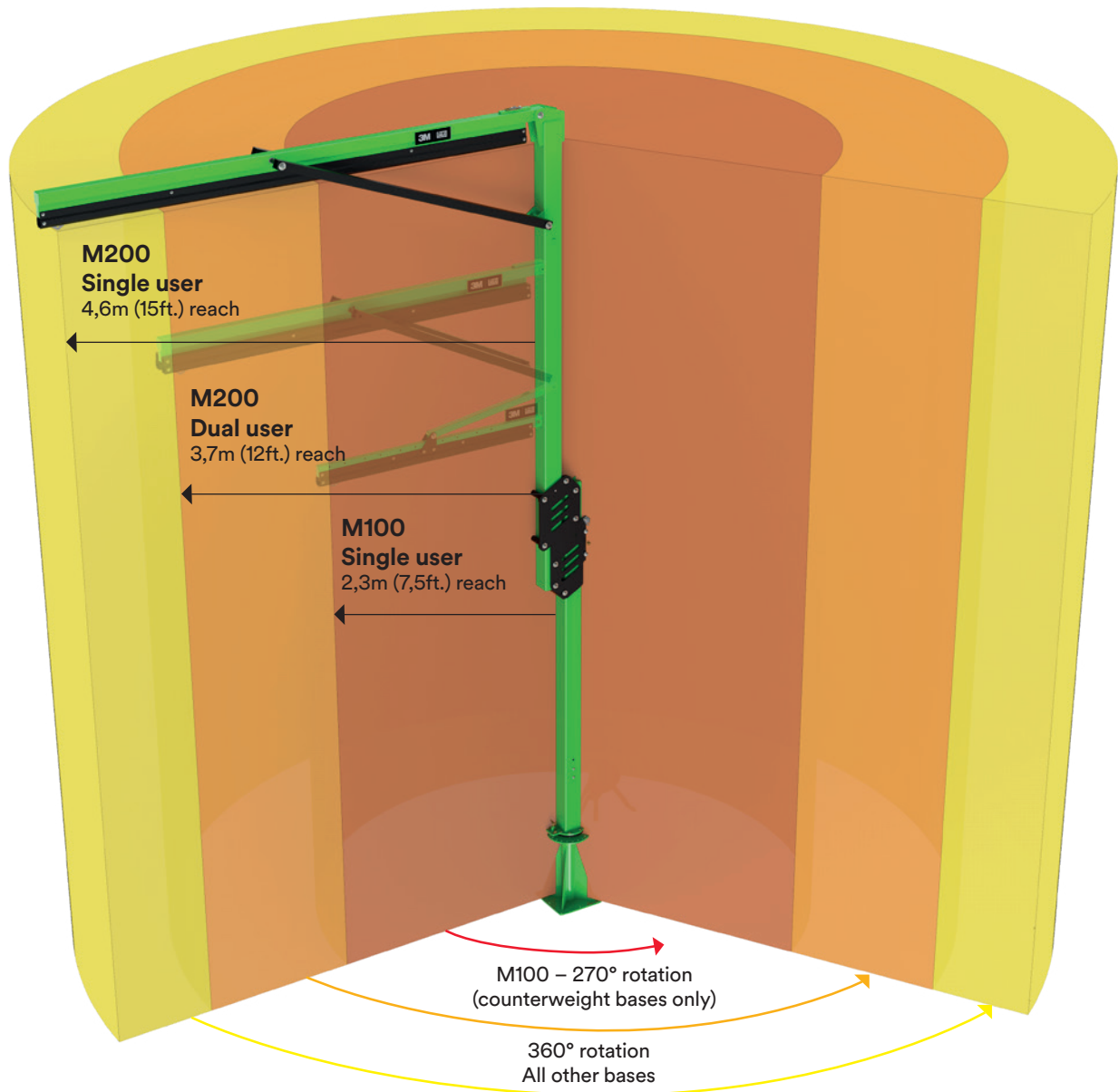

Dual user rated

Select M200 models only

- ▶ Helps increase worksite efficiency and safety for multiple workers
- ▶ Provides additional working coverage compared to previous 3M models
- ▶ Dual user systems contain two independent bypassing horizontal rails rated for one worker each

M100 Modular Jib Systems

Model	Total system weight	Max. component weight	Offset/Reach (A)	Height (B)	Mast rotation range	Max. number of users	SRL maximum arresting force
M100	2,266kg (4,995lbs.)	1,404kg (3,095lbs.)	2,3m (7.5ft.)	Up to 9,1m (30ft.)	270° with counterweight base 360° with others	1	6kN (1,350lbs.)

1 Choose from 6 interchangeable mast options.

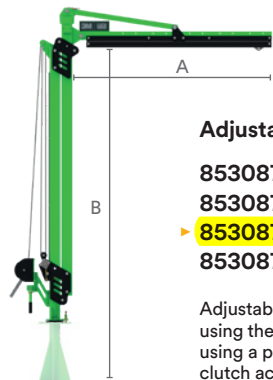

Adjustable height, single user masts

- 8530874 3–4,6m (7,5–15ft.)
- 8530875 3,8–6,1m (12,5–20ft.)
- ▶ **8530876** 4,6–7,6m (15–25ft.)
- 8530877 5,3–9,1m (17,5–30ft.)

Adjustable height masts are adjusted easily using the integrated hand crank winch, or by using a power drill with the optional overload clutch accessory equipped.

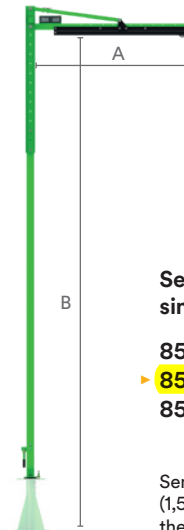

Semi-fixed height, single user masts

- 8530882 4,6–6,1m (15–20ft.)
- ▶ **8530883** 6–7,6m (20–25ft.)
- 8530884 7,6–9,1m (25–30ft.)

Semi-fixed masts offer a small amount (1,5m or 5ft.) of adjustment to optimise the anchor height during installation.

▶ = Model shown

2 Choose from 5 interchangeable base options.

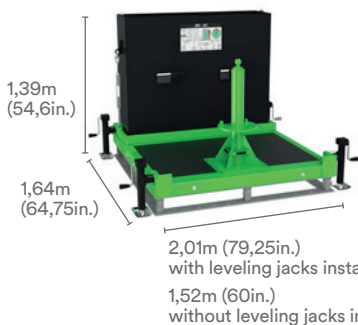

Portable Counterweight Base*
with concrete fill **8530870**
without concrete **8530869**

*Portable Counterweight Base includes leveling jacks

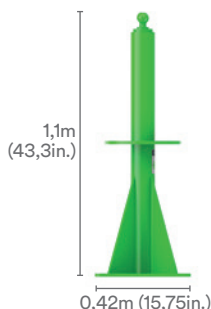

Floor Mounted Base
8530871

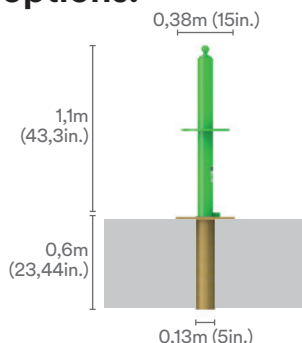

Flush Mounted Base
8530872

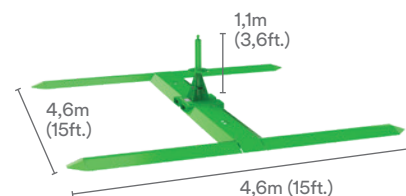

Outrigger Base
8530873

3 Choose your accessories.

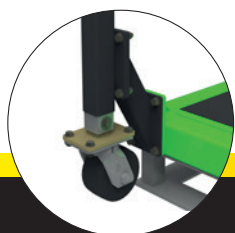

Smooth Surface
Caster Kit
8530908

Allows counterweight base systems to be maneuvered into tight spaces on smooth surfaces, kit of 4 wheels.

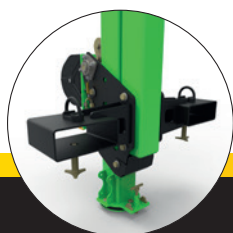

Forklift Pocket Mast
Transport Kit
8530911

Allows mast to be separated from the base and transported vertically using a forklift.



Overload
Clutch
8512936

Required to raise and lower adjustable masts with a power drill (drill not included).



Counterweight Box
Lifting Ring Kit
8530914

Allows counterweight box to be moved with overhead lifting equipment. Includes two rings per kit. One kit needed per counterweight system.

Easier transport.

Patent-pending weight distribution simplifies transport using 2,5 tonnes rated (or 5,000lbs.) forklift for all counterweight models.

- ▶ Navigate indoor smooth surface spaces with optional caster wheel kit

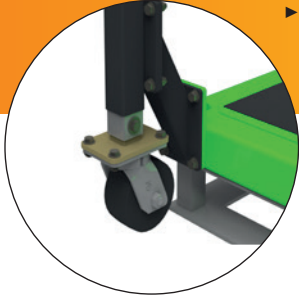

M100 Systems

- ▶ Can be transported in one piece with a 2,5 tonnes (or 5,000 lbs.) forklift



M100 System maximum weights:

- ▶ Complete system 2270kg (5,000lbs.)
- ▶ System without counterweight 866kg (1,910lbs.)
- ▶ Counterweight box alone 1,404kg (3,095lbs.)

M200 Systems

- ▶ Can be transported in one piece with a large lift

Or

- ▶ Separated into individual components and transported with a 2,5 tonnes (or 5,000 lbs.) forklift



M200 System maximum weights:

- ▶ Complete system 5,746kg (12,668lbs.)
- ▶ System without counterweight 1,210kg (2,668lbs.)
- ▶ Counterweight box alone 2,268kg (5,000lbs.) each

Important: counterweights must be installed prior to use and storage. They must only be removed for transportation.

Counterweight box alone = 2,268kg (5,000lbs.) (two boxes total)



Maximum system weight with counterweights removed = 1,210kg (2,668lbs.)

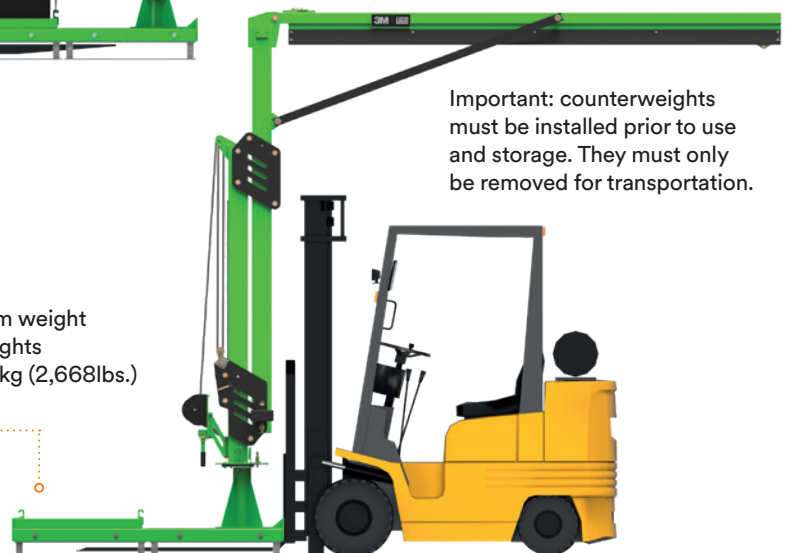

M200 Modular Jib Systems

Model	Total system weight	Max. component weight	Offset/Reach (A)	Height (B)	Mast rotation range	Max. number of users	SRL maximum arresting force
M200	5,746kg (12,668lbs.)	2,268kg (5,000lbs.)	4,6m (15ft.) Single user models 3,7m (12ft.) Dual user models	Up to 9,1m (30ft.)	360° for all bases	1 or 2 depending on model	6kN (1,350lbs.)

1 Choose from 14 interchangeable mast options.

▶ = Model shown

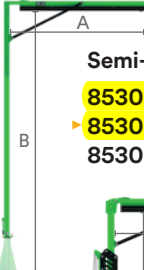
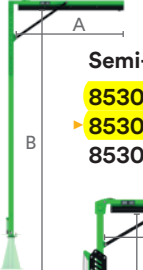
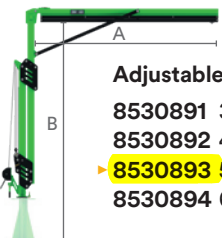
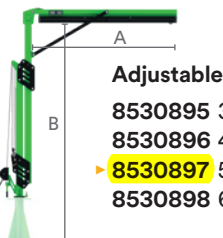
 <p>Semi-fixed height, single user masts</p> <p>8530899 4,6–6,1m (15–20ft.) ▶ 8530900 6,1–7,6m (20–25ft.) 8530901 7,6–9,1m (25–30ft.)</p>	 <p>Semi-fixed height, dual user masts</p> <p>8530902 4,6– 6,1 m (15–20ft.) ▶ 8530903 6,1–7,6m (20–25ft.) 8530904 7,6–9,1m (25–30ft.)</p>	<p>Semi-fixed masts have a small amount (1,5m or 5ft.) of adjustment to optimise the anchor height during installation.</p>
 <p>Adjustable height, single user masts</p> <p>8530891 3,8–4,6m (12,3–15ft.) 8530892 4,5–6,1m (14,8–20ft.) ▶ 8530893 5,3–7,6m (17,3–25ft.) 8530894 6–9,1m (19,8–30ft.)</p>	 <p>Adjustable height, dual user masts</p> <p>8530895 3,8-4,6m (12–15ft.) 8530896 4,5-6,1m (14,8–20ft.) ▶ 8530897 5,3-7,6m (17,3–25ft.) 8530898 6-9,1m (19,8–30ft.)</p>	<p>Adjustable height masts are adjusted easily using the integrated hand crank winch, or by using a power drill with the optional overload clutch accessory equipped.</p>

2 Choose from 4 interchangeable base options.

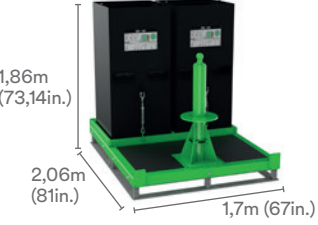
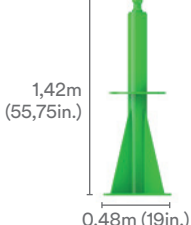
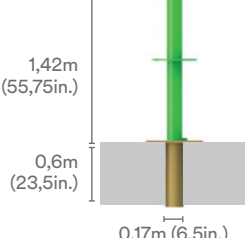
 <p>1,86m (73,14in.) 2,06m (81in.) 1,7m (67in.)</p> <p>Portable Counterweight Base* With concrete fill 8530887 Without concrete 8530886</p> <p><small>*Portable Counterweight Base optional leveling jacks sold separately</small></p>	 <p>1,42m (55,75in.) 0,48m (19in.)</p> <p>Permanent Floor Mounted Base 8530888</p>	 <p>0,51m (20in.) 1,42m (55,75in.) 0,6m (23,5in.) 0,17m (6,5in.)</p> <p>Permanent Flush Mounted Base 8530889</p>
---	--	--

3 Choose your accessories.

				
<p>Jack Stabilising Kit 8530907</p> <p>Designed to stabilise and level counterweight base systems on slightly uneven surfaces, kit of 4 jacks.</p>	<p>Smooth Surface Caster Kit 8530908</p> <p>Allows counterweight base systems to be maneuvered into tight spaces on smooth surfaces, kit of 4 wheels.</p>	<p>Forklift Pocket Mast Transport Kit 8530912</p> <p>Allows mast to be separated from the base and transported vertically using a forklift.</p>	<p>Overload Clutch 8512936</p> <p>Required to raise and lower adjustable masts with a power drill (drill not included).</p>	<p>Counterweight Box Lifting Ring Kit 8530777</p> <p>Allows counterweight box to be moved with overhead lifting equipment. Includes four rings per kit. One kit needed per counterweight system.</p>

3M Fall Protection

Capital Safety (Northern Europe) Limited
3M Centre, Cain Road
Bracknell, Berkshire, RG12 8HT, UK
Phone: +33(0)4 83 58 08 08 Email: informationfallprotection@mmm.com Web: 3M.com/FallProtection

Capital Safety Group (EMEA)
Le Broc Center, Bâtiment A, Z.1. 1re Avenue – BP15
06511 Carros Le Broc, Cedex, FRANCE

